



# INSTALLATION INSTRUCTIONS

Accessory

**SIDE STEPS (SQUARE TYPE)**  
P/N 08L03-SJC-100B

Application

**2014 RIDGELINE**

Publications No.

**All 50358**

Issue Date

**AUG 2013**

## PARTS LIST

Left side step

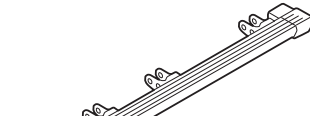

Right side step

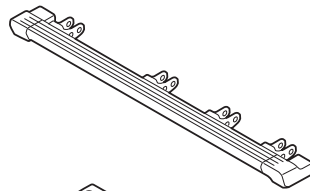

6 Brackets A

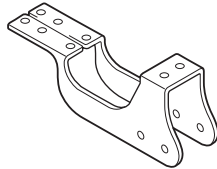

2 Brackets B



62 Flange bolts



32 Flange nuts



2 Knurled threaded inserts



## TOOLS AND SUPPLIES REQUIRED

Ratchet

13 mm Socket

Extension

13 mm Combination wrench

Blanket

Torque wrench

Clip remover

Rivet nut special tool

27 mm Wrench

## INSTALLATION

**Customer Information:** The information in this installation instruction is intended for use only by skilled technicians who have the proper tools, equipment, and training to correctly and safely add equipment to your vehicle. These procedures should not be attempted by "do-it-yourselfers".

### NOTE:

- Thoroughly clean the bottom of the body from the rear of the front wheels forward to the front of the rear wheels.
  - Be careful not to damage the body finish. To prevent damage, place a blanket under the side step during the installation.
  - These instructions show the left side step being installed; the same procedure applies to installing the right side step.
1. Under the vehicle, locate and remove the grommet from the body. Do steps 2 through 5 to install the knurled threaded insert into the grommet hole.

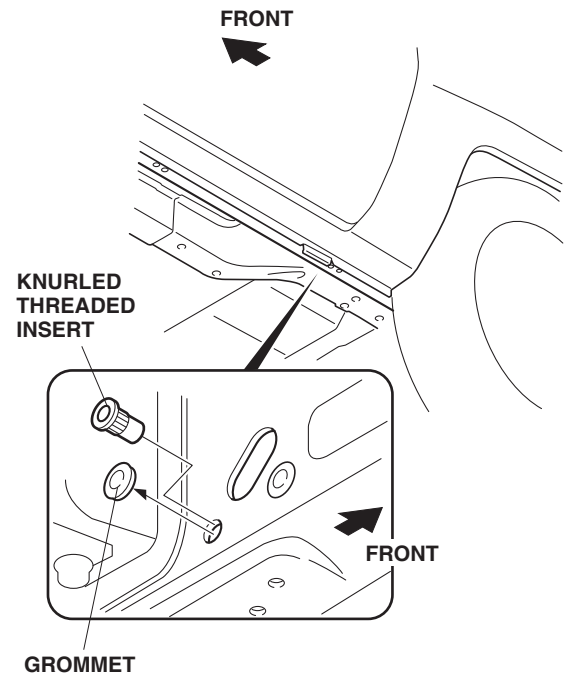

- Screw the knurled threaded insert onto the mandrel of the tool as shown.

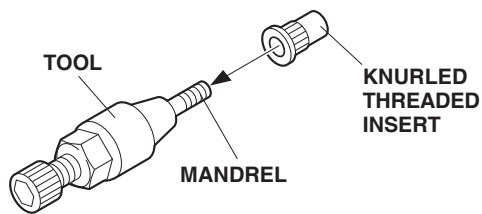

- Insert the knurled threaded insert into the hole in the vehicle panel and install the hex wrench on the tool.

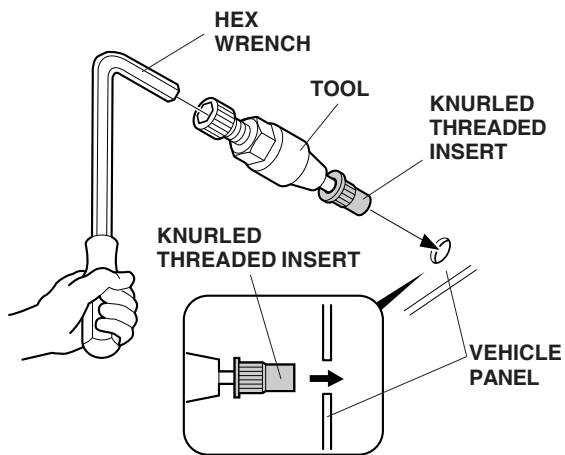

- Holding the tool with the hex wrench, turn the 27 mm wrench clockwise and install the knurled threaded insert in the vehicle panel.

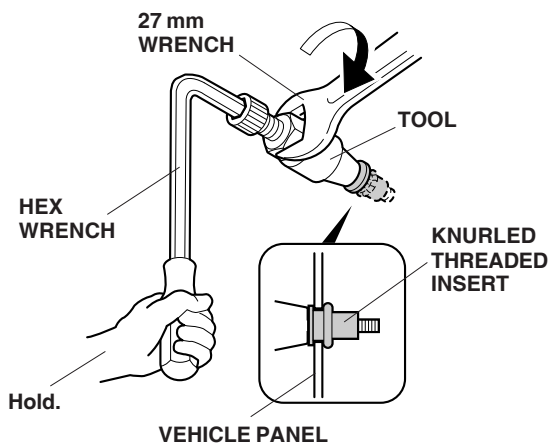

- Remove the tool from the knurled threaded insert by turning the hex wrench counterclockwise.

- Remove and discard the eight clips from the bottom of the body.

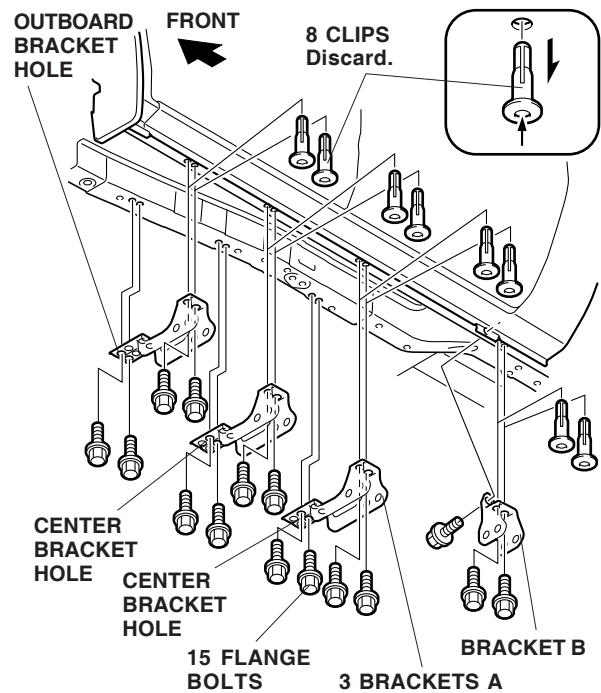

- Install three brackets A and one bracket B to the body using 15 flange bolts. Thread the flange bolts in about 3 to 4 threads. When installing brackets A, use the outboard bracket holes for the front bracket, and the center bracket holes for the center and rear brackets.

- Install the side step to the brackets using 16 flange bolts and 16 flange nuts. Thread the nuts on about 3 to 4 threads.

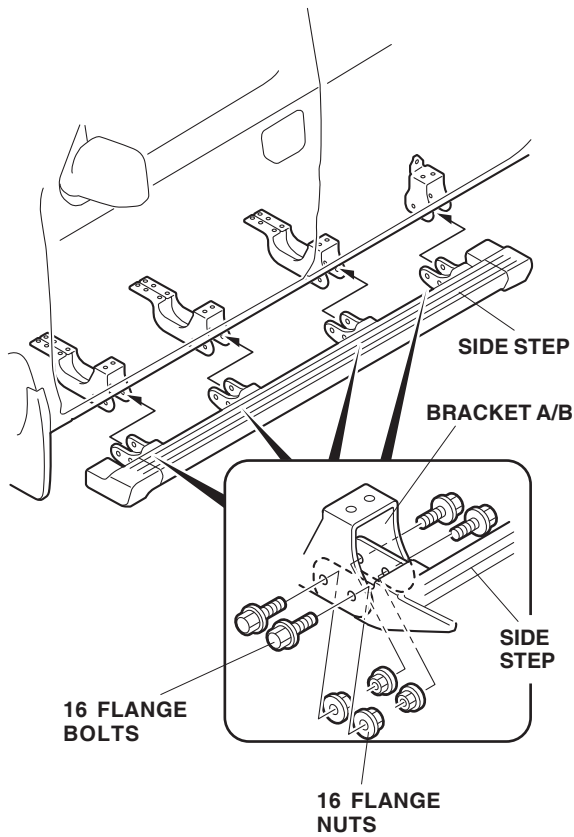

- Adjust the location of the left side step so there is even clearance between the side step and body, then tighten the flange bolts you installed in step 7. Torque 14 flange bolts to 27 N·m (20 lbf·ft), and the one remaining flange bolt to 7 N·m (5 lbf·ft) as shown.

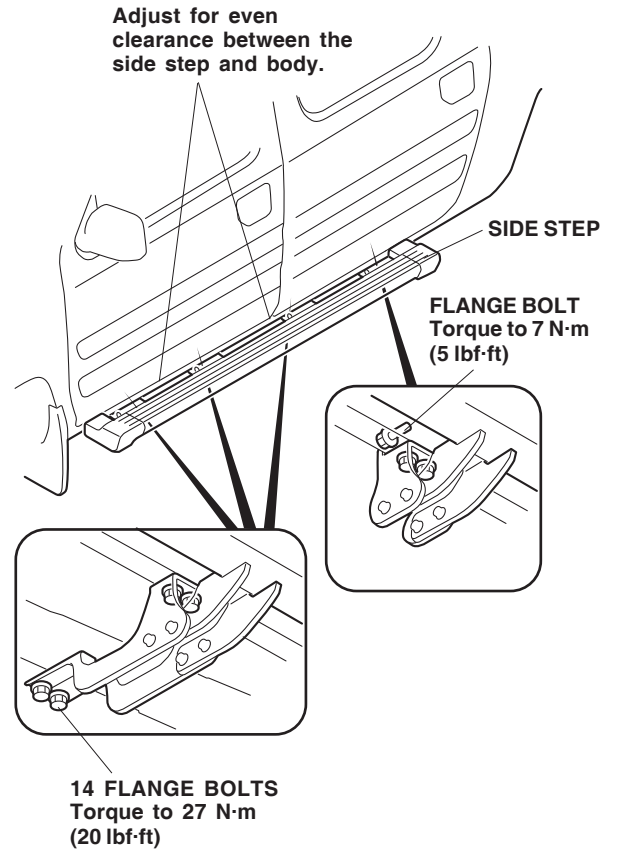

- Torque the 16 flange bolts you installed in step 8 to 27 N·m (20 lbf·ft).
- Repeat steps 1 through 10 to install the side step on the right side of the vehicle.